

## Opera Ardesia Pietra

### Opera Ardesia Pietra

#### DATI TECNICI / TECHNICAL DATA

Codice Code	BT01P
Materiale Material	Terra Cotta
Dimensioni mm (a x b) Dimensions mm (a x b)	465x285
Peso unitario kg Unit weight kg	4,3
Passo orizzontale mm Horizontal pitch mm	243
Passo verticale mm Vertical pitch mm	370 (350-385)
Pezzi al m <sup>2</sup> Pieces for sqm	11
Pallet: n° pezzi / peso kg Pallet: n° pieces / weight kg	168 / 735
Garanzia anni Years warranty	10
Resistenza al fuoco esterno Resistance to external fire	B roof
Reazione al fuoco Reaction to fire	A1
Lunghezza tolleranza media % Medium tolerance lenght %	≤ 2%
Rettilinearità longitudinale media % Medium longitudinal straightness %	≤ 1,5%
Carico medio per rottura a flessione kN Average load for break up flexion kN	> 280 Kgf
Valore medio di impermeabilità all'acqua Average value water impermeability	< 0,600
Categoria di impermeabilità all'acqua Water resistance category	1
Resistenza al gelo: livello / metodo / n° cicli Frost resistance: level / method / n° cycles performed	L1 / E /150
SRI Solar Reflectance Index	20



## VOCE DI CAPITOLATO / TECHNICAL SPECIFICATIONS

Fornitura di manto di copertura discontinuo in laterizio costituito da tegole Opera caratterizzate da superficie piana, stampate in cotto di lunghezza ~465 mm e di peso ~4,3 kg in numero di ~11 pezzi al metro quadrato e comprendente i relativi pezzi speciali, quali colmi, finali, aeratori, membrana impermeabilizzante sotto manto a perfetta tenuta ecc., a completamento della copertura. Le tegole devono essere fornite della relativa garanzia e rispondere alle prescrizioni della normativa UNI EN 1304 "Tegole di laterizio e relativi accessori" e in generale essere conformi alle normative vigenti e loro eventuali successive modifiche, tipo tegole Opera Pietra Ardesia di Industrie Cotto Possagno S.p.A. Per le altre tipologie di tegole, per la POSA IN OPERA e per la GARANZIA fare riferimento al Catalogo Generale Coperture o al sito [www.cottopossagno.com](http://www.cottopossagno.com)

Supply of a discontinuous clay roof covering consisting of Opera tiles, characterized of flat surface, moulded in terracotta, length: ~465 mm, weight: ~4.3 kg; ~11 pieces/sq.m, and also including related special pieces, such as ridge tiles, end tiles, aerators, leak-proof waterproofing underlying membrane etc. to complete roofing. The tiles must be supplied together with the corresponding warranty and meet the requirements of UNI EN 1304 on "Clay roofing tiles and fittings" and, in general, they must comply with the regulations in force and their subsequent amendments, such as Opera Pietra Ardesia tile by Industrie Cotto Possagno S.p.A. For any other type of tiles, for INSTALLATION and WARRANTY refer to General Catalogue or website [www.cottopossagno.com](http://www.cottopossagno.com)

### Pezzi speciali Opera Special pieces

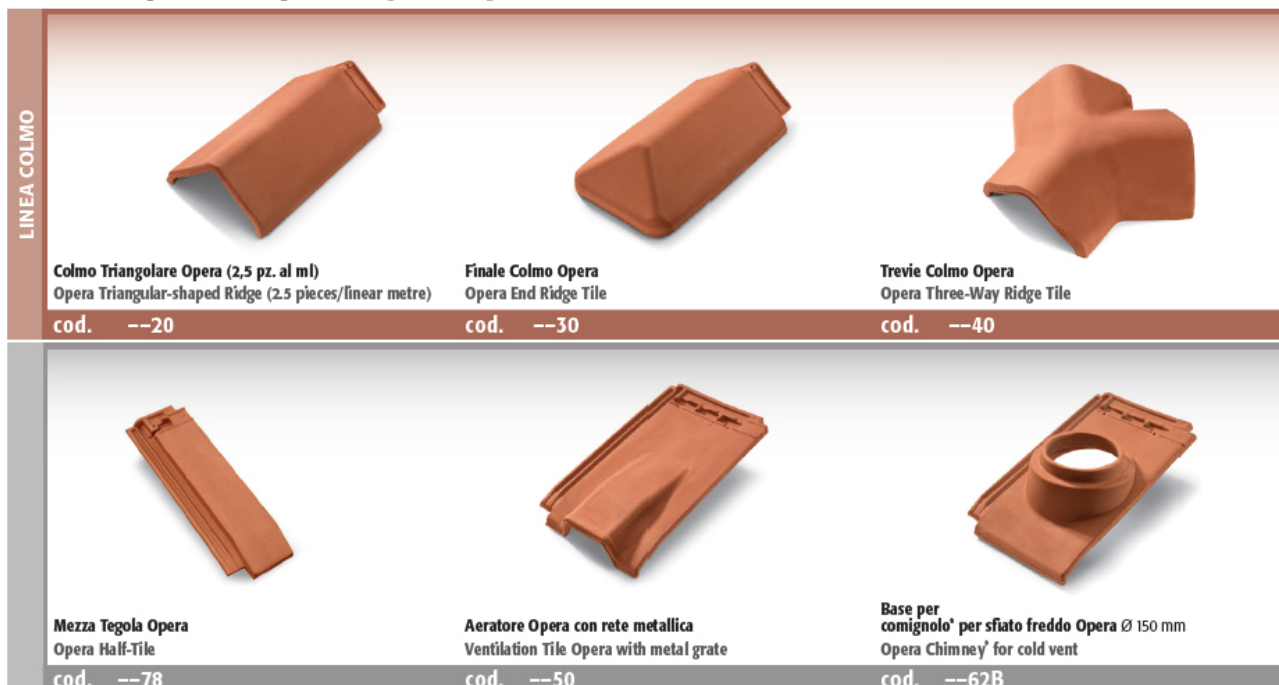

\*Da non utilizzare per camino con fumi caldi. | \*Not to be employed with hot fumes.

## ISTRUZIONI DI POSA / INSTALLATION INSTRUCTIONS

### Posa in opera **Opera** Laying

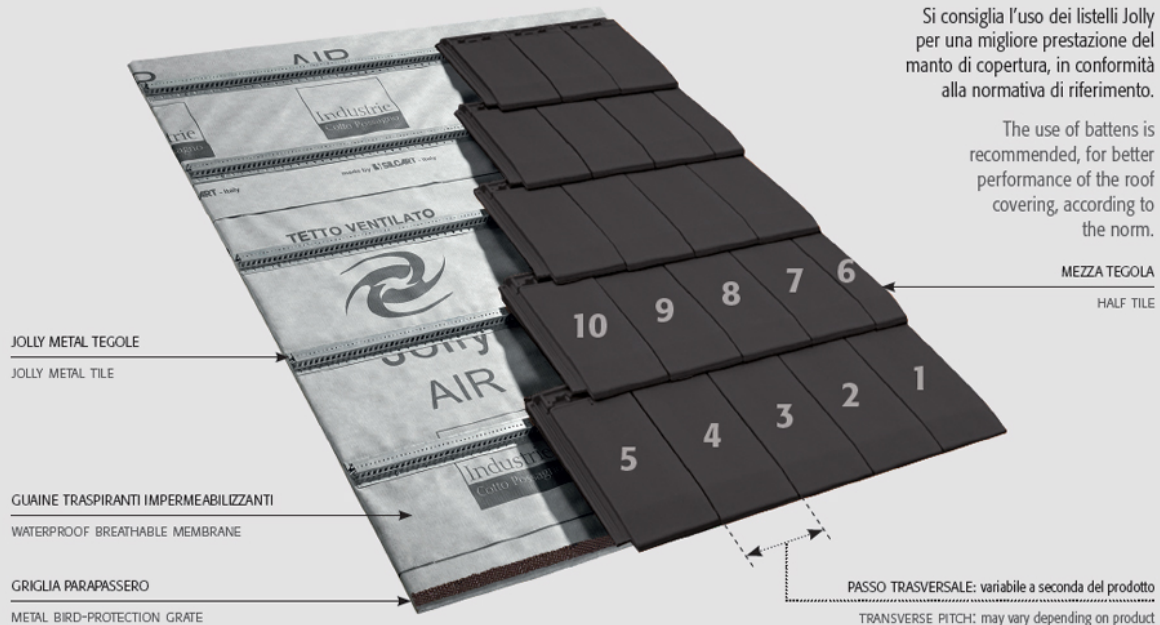

Si consiglia l'uso dei listelli Jolly per una migliore prestazione del manto di copertura, in conformità alla normativa di riferimento.

The use of battens is recommended, for better performance of the roof covering, according to the norm.

Le tegole piane, per le loro caratteristiche tecniche - morfologiche richiedono sempre l'applicazione di una membrana impermeabilizzante sotto manto a perfetta tenuta. L'Azienda non risponde dei problemi derivanti dalla mancata osservanza di tale prescrizione. Per pendenze comprese tra 30% e 40% si raccomanda l'uso della membrana impermeabilizzante jolly air plus.

The plain-tiles requires always the application of a leak-proof waterproofing underlying membrane, due to their technical - morphological features. Our company does not hold responsibility for problems due to non-observance of such indications. In the event of gradients between 30% and 40%, the use of a jolly air plus leak-proof waterproofing underlying membrane is required.

#### COLMO TRIANGOLARE OPERA

RIDGE TILE

TEGOLA OPERA

OPERA TILE

### Sezione linea di colmo Rooftop section

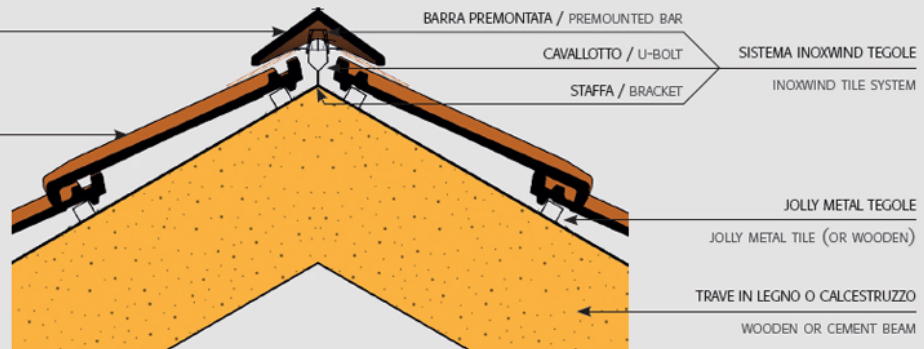

### Sezione linea di gronda Gutter line section

TEGOLA OPERA

OPERA TILE

LISTELLO LINEA DI GRONDA

EAVE LINE BATTEN

GRONDA

GUTTER

PASSO LONGITUDINALE (CONSIGLIATO): ~370 mm  
LONGITUDINAL PITCH (RECOMMENDED): ~370 mm

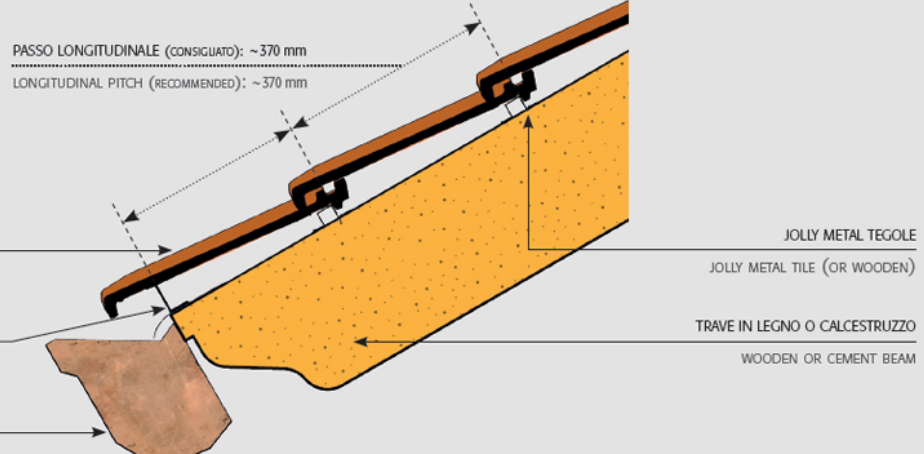

### Tabella delle pendenze per i manti di copertura in tegole laterizie Chart of slopes for clay roofing tiles

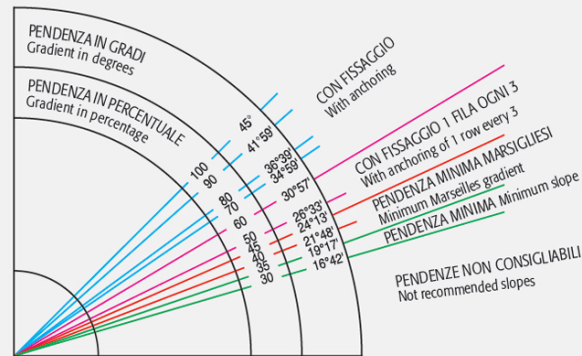

Le pendenze da adottare e le sovrapposizioni sono indicate nella tabella sopra riportata. Per quanto riguarda la forza del vento si fa riferimento alla circolare del Ministero dei Lavori Pubblici che suddivide il territorio nazionale in zone climatiche (Circ. n. 22631 del 24/05/82).

Slopes to be used and overlays are indicated in the table above. Concerning the strength of the wind, refer to the Ministry of Public Works circular that divides the national territory into climatic zones (Circular n. 22631 dated 24.05.82).

### MISURE DI PROTEZIONE / PROTECTIVE MEASURES UNI EN ISO 7010:2012



W022



M002



M010



M015



M009



M008



M004



M014



M003



M016